

SMART CAMERA SMARTX-10 SERIES

WebSpect software is integrated in SmartX-ARM series can deliver a rugged and highly flexible machine vision solution with good cost value and ease of use in a compact form factor.

- o Remotely setup and configure parameter on PC or mobile device via Wi-Fi using web browser.
- o Real-Time Inspection Data and processes can be viewed immediately and adjust configuration anywhere, anytime.

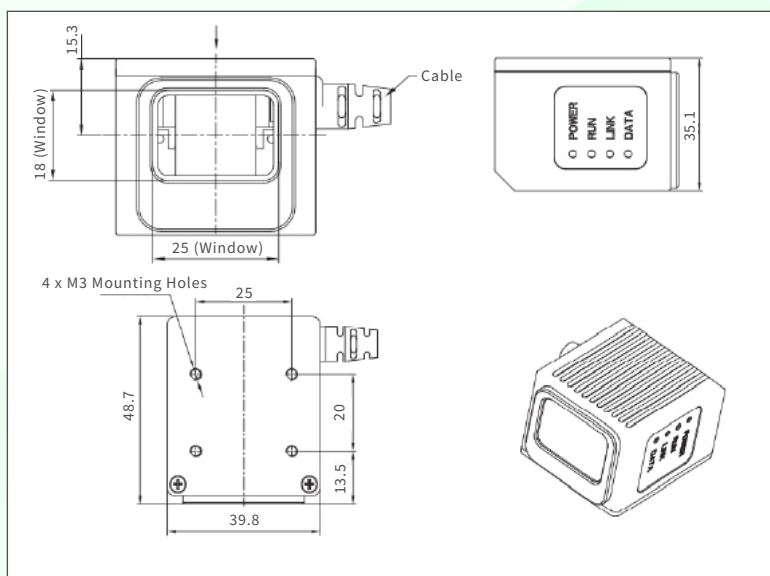
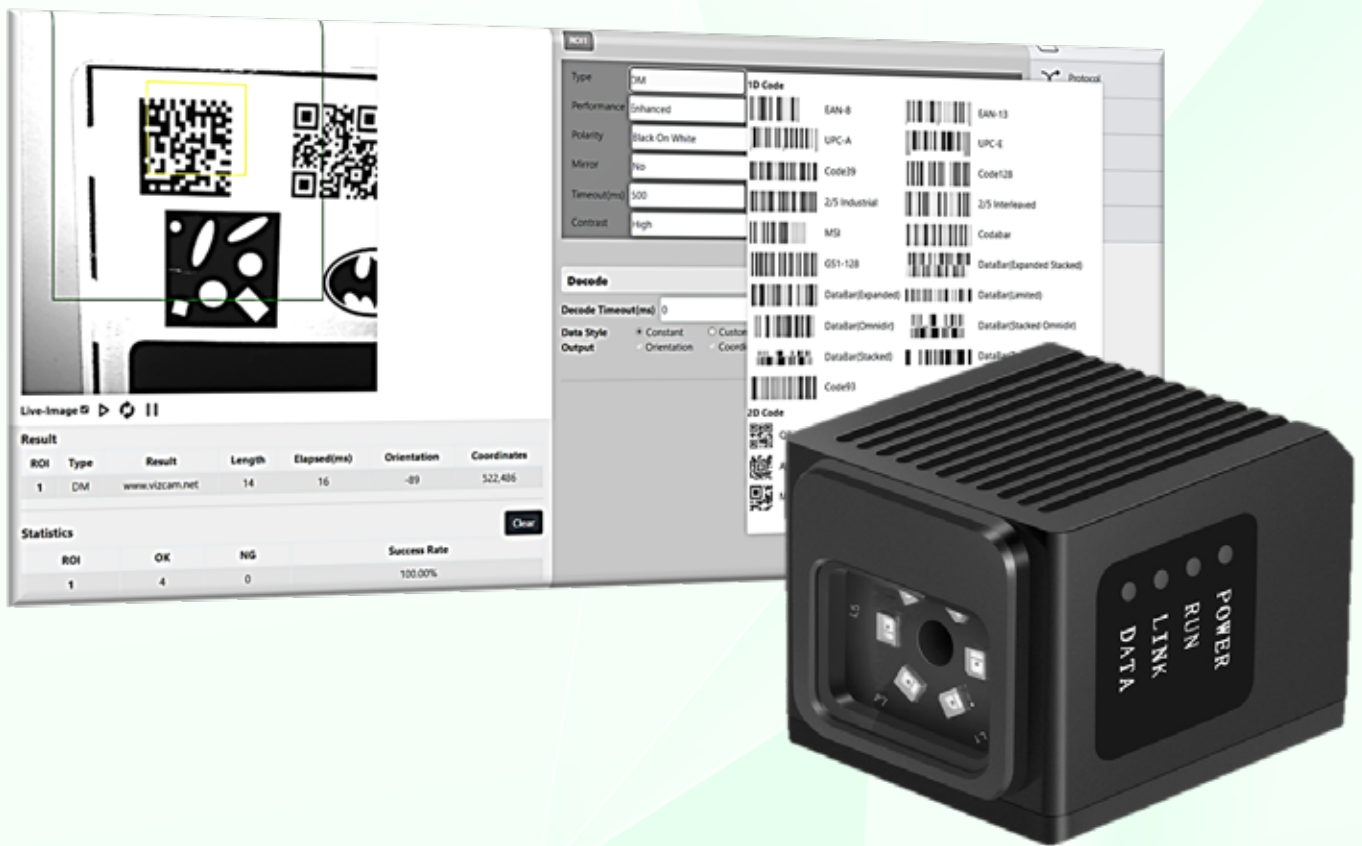

It offers 1D/2D code reading with high computing speed and flexibility.

Barcode:

EAN-8, EAN-13, UPC-A, UPC-E, 2/5Industrial, 2/5Interleaved, Code39, Code93, Code128, MSI, GS1-128, Codabar, DataBar

2D code

QR, DataMatrix, Aztec, PDF417, MicroQR, DotCode

HARDWARE SPECIFICATION

Description	SX10-010M050
Processor Type	ARM Cortex A7, 1.2GHz Quad-Core CPUs
Memory / Storage	512MB DDR3 RAM & 16GB
Image Size	1.3MP
Resolution	1080 x 1280
Sensor Size	1/2.7" CMOS
Sensor Frame Rate	50fps
Ethernet Port	10/100M
Communication	TCP / RS232
Isolated I/Os	1IN / 3OUT
Lighting Control	Embedded Lighting
Power Supply	24VDC, 1.7W
Barcode Reading Type	EAN-8, EAN-13, UPC-A, UPC-E, 2/5Industrial, 2/5Interleaved, Code39, Code93, Code128, MSI GSI-128, Codebar, Databar
2D Code Reading Type	QR, DataMatrix, Aztec, PDF417, MicroQR, DotCode
Dimensions	39.8 x 29.6 x 48.7mm
Accessories	I/O Cable, 3m
Weight	125gm

S/N	Part Number	Resolution	Lens Type	Working Distance (mm)	FOV (mm)
1	SX010-010M050-6-060	1080 x 1280	7.1mm	60	31 x 37
2	SX010-010M050-6-100			100	50 x 60
3	SX010-010M050-6-150			150	75 x 90
4	SX010-010M050-6-200			200	100 x 119
5	SX010-010M050-6-250			250	125 x 148
6	SX010-010M050-15-060		15mm	60	11 x 13
7	SX010-010M050-15-100			100	20 x 24
8	SX010-010M050-15-150			150	30 x 35
9	SX010-010M050-15-200			200	40 x 47
10	SX010-010M050-15-250			250	50 x 59

CONTACT US



Scan for More!



Corporate Headquarter (Singapore)

Inspiraz Technology Pte Ltd

Blk 19, Kallang Avenue #06-163, Singapore 339410

www.vizcam.net +65 6297 0880 sales@inspiraz.com



China Headquarter (Shanghai)

启毅视觉科技(上海)有限公司

上海市静安区梅园路 228 号

(企业广场) 2618 室

China Office (Shenzhen)

深圳市南山区桃园路 1号

西海明珠大厦 F 座 11 楼 C13

www.inspiraz.cn +86 021 5299 0181 sales@inspiraz.cn



Korea Office (Seoul)

#1109, B Building 201

Songpa Gu Seoul, Korea 05854

www.vizcam.co.kr +82 2 2264 2563~5 sales@vizcam.co.kr

